

IP67 M12 CONNECTOR IEC 60947-5-2 (CODE 'J')

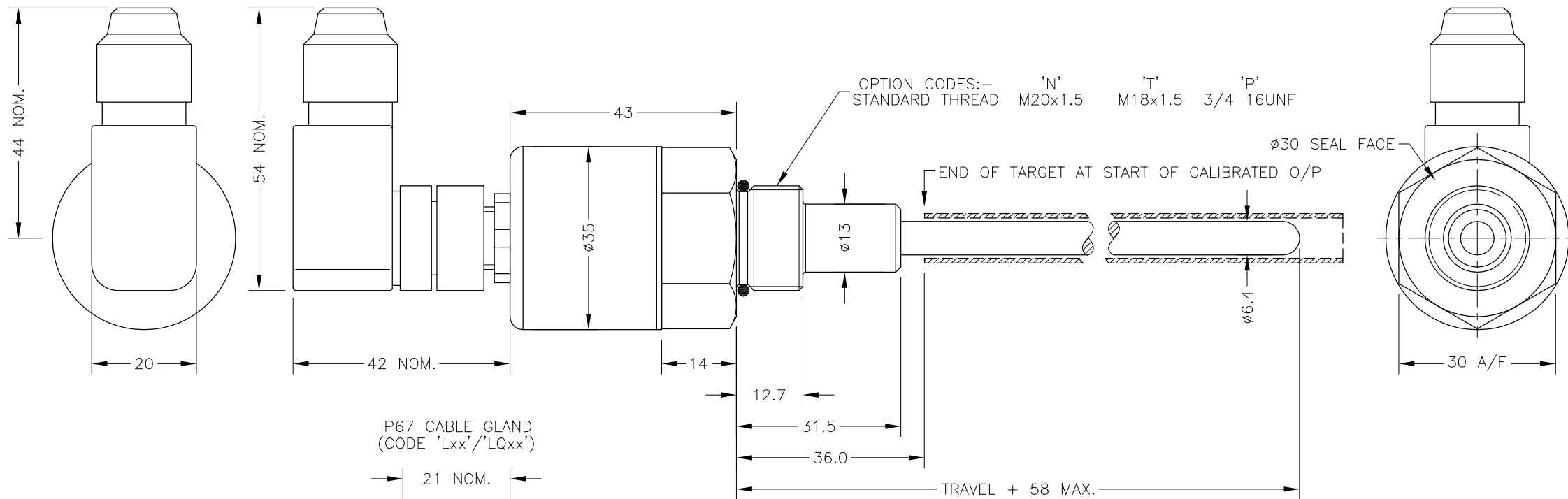

IP67 CABLE GLAND
(CODE 'Lxx'/'LQxx')

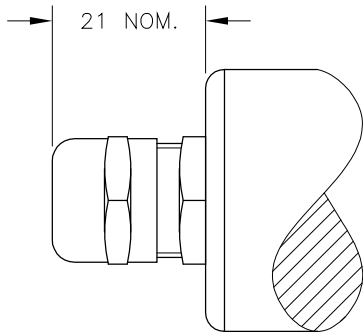

IP67 SHORT CABLE GLAND
- AXIAL (CODE 'Mxx'/'MQxx')

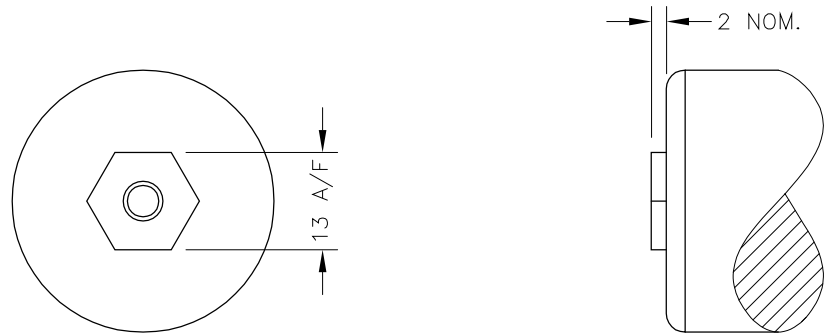

OPTION 'W' FLANGE ILLUSTRATED; SEE TG24-11 FOR DETAILS TO SPECIFY TARGET TUBES.
SEE P100-12 FOR DETAILS TYPICAL TARGET TUBE MOUNTING ARRANGEMENTS

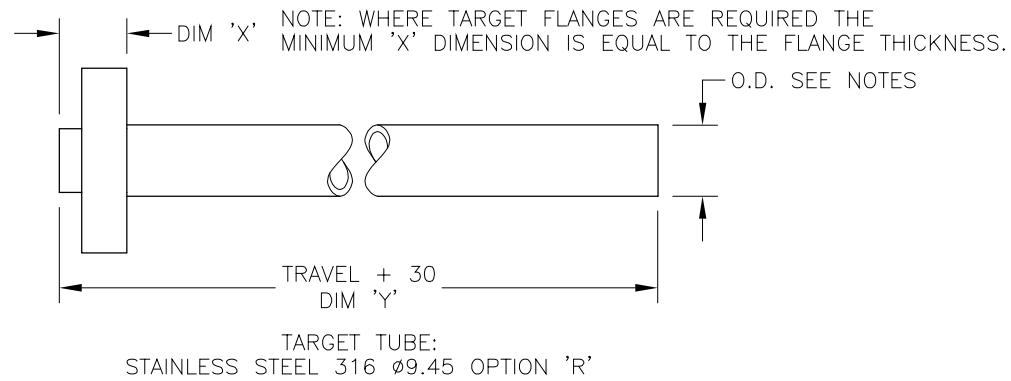

ELECTRICAL OPTIONS/ SPECIFICATIONS

OUTPUT	SUPPLY
0.5 TO 4.5V RATIOMETRIC	5V
SUPPLY CURRENT	12mA TYP. 20mA MAX.

CABLE: 0.2mm², O/A SCREEN, PUR JACKET - SUPPLIED WITH 50cm OR REQUIRED LENGTH IN cm (15000cm MAX).
STANDARD 3-CORE: JACKET 04mm BLACK e.g. 'L50'
OPTIONAL 5-CORE: JACKET 04.6mm BLUE e.g. 'LQ50'

CABLE/CONNECTOR* CONNECTIONS;

3 CORE	5 CORE	CONNECTOR	
RED	RED	:1	+Ve
-	ORG	:1	+SENSE (5-WIRE ONLY)
BLACK	BLACK	:3	0V
-	GRY	:3	-SENSE (5-WIRE ONLY)
WHITE	WHITE	:2	OUTPUT
SCREEN	SCREEN	:4	BODY

*CONNECTORS; MAXIMUM CONDUCTOR CROSS SECTION 0.75mm²

RANGE OF DISPLACEMENT FROM 0-5mm TO 0-800mm e.g.76, IN INCREMENTS OF 1mm.

BODY MATERIAL: STAINLESS STEEL.

NOTE:- READ INSTALLATION SHEET E100-19 FOR FULL INSTRUCTIONS FOR USE.

ATEX / IECEx APPROVED TO

II 1GD
Ex ia IIC T4 Ga (Ta= -40° to +80°C)
Ex ia IIIC T135°C Da (Ta= -40° to +80°C)
Ui 11.4V, Ii 0.2A, Pi 0.51W

APPROVED FOR USE IN CONJUNCTION WITH A GALVANICALLY ISOLATED BARRIER.

NOTE: APPROVAL ONLY APPLIES AT NORMAL ATMOSPHERIC PRESSURE!

F	OPTION 'S' REMOVED - RAN1035.	PDM
G	RANGE WAS 20-600 RAN1056	RDS
H	TARGET NOTES AMENDED ~ RAN1114	PDM
J	5-CORE OPTION ADDED ~ RAN1102	PDM
K	OPTION 'M' ADDED ~ RAN1166, RANGE NOTE AMENDED ~ RAN1200	PDM
L	HEX. LENGTH 14 WAS 15 ~ RAN1160	PDM



DRAWINGS NOT TO BE CHANGED WITHOUT REFERENCE TO THE CHANGE PROCEDURE.
CHANGES TO PARTS USED IN INTRINSICALLY SAFE PRODUCT MUST BE APPROVED BY THE AUTHORISED PERSON
THIS IS AN UNCONTROLLED PRINT AND WILL NOT BE UPDATED.

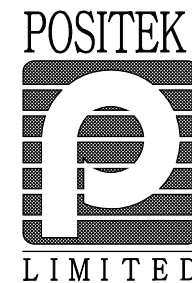

F	29/06/15		CHECKED BY	X	±0.4
G	9/11/15		RDS	X.X	±0.2
H	18/10/16			X.XX	±0.1
					DIMS mm
J	05/04/17	DESCRIPTION			
K	29/08/17	E100 INTRINSICALLY SAFE			
L	11/10/17	CYLINDER LINEAR POSITION SENSOR			
SCALE 10mm		DRAWING NUMBER		E100-11	REV L
				SHEET 1	OF 1

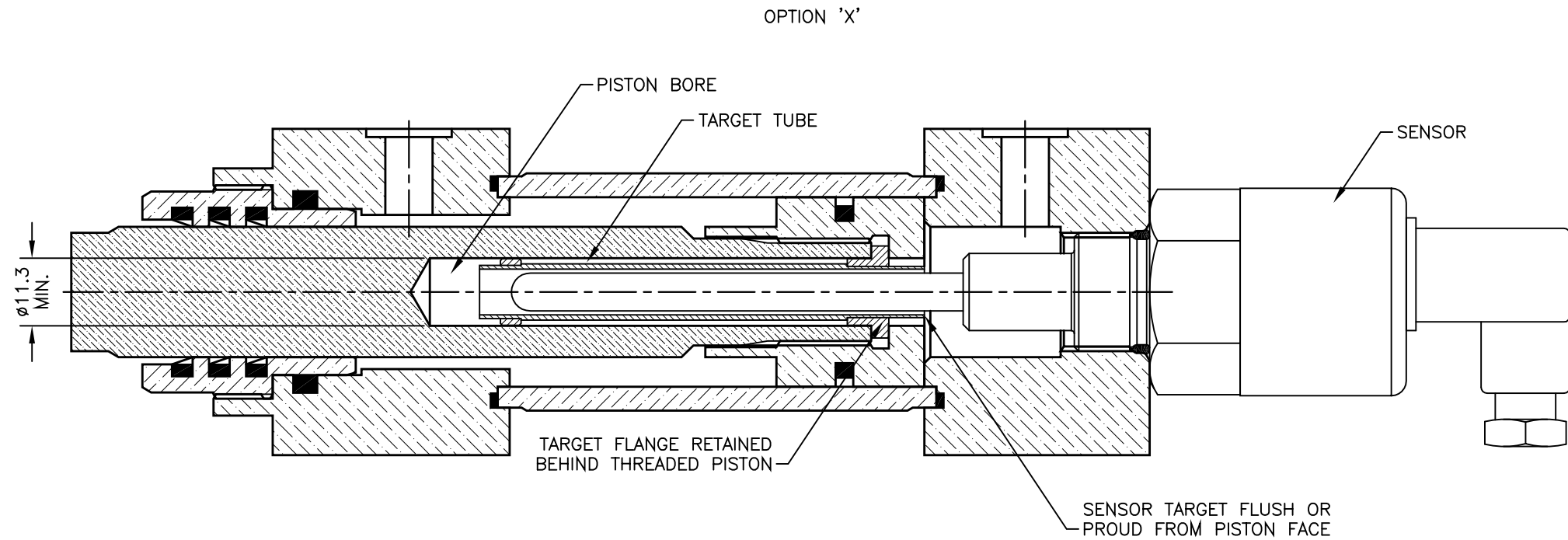
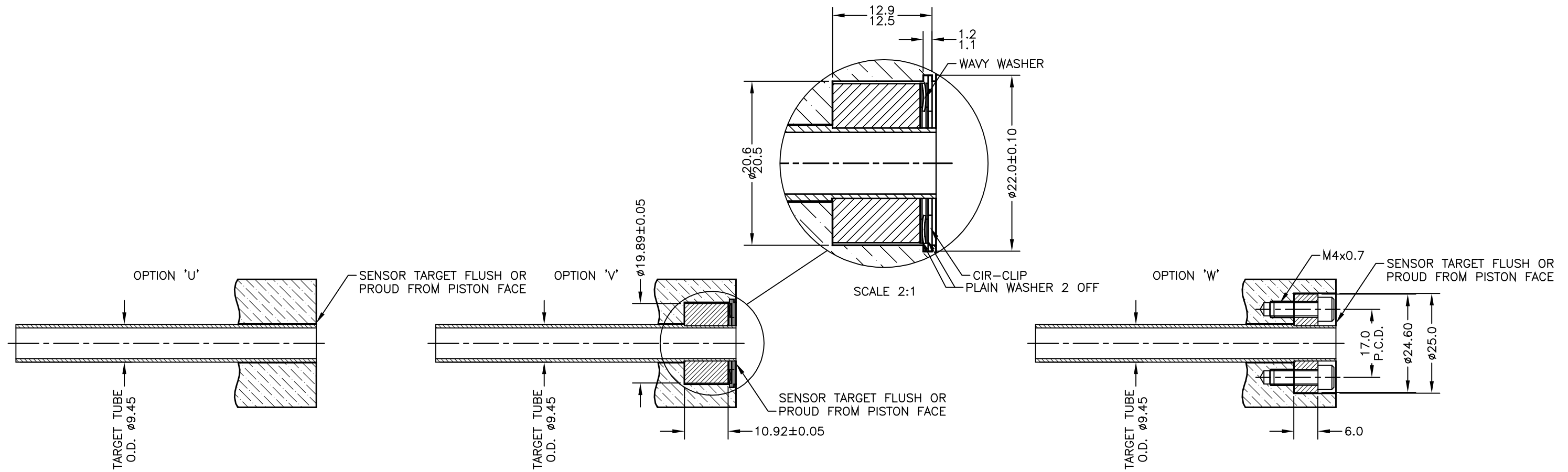

A	FIRST ISSUE.	RDS
B	REDRAWN.	PDM
C	WORDING AMMENDED	RDS
D	TARGET NOTES AMENDED - RAN1349	PDM

DRAWINGS NOT TO BE CHANGED WITHOUT REFERENCE TO THE CHANGE PROCEDURE.
 CHANGES TO PARTS USED IN INTRINSICALLY SAFE PRODUCT MUST BE APPROVED
 BY THE AUTHORISED PERSON
 THIS IS AN UNCONTROLLED PRINT AND WILL NOT BE UPDATED.

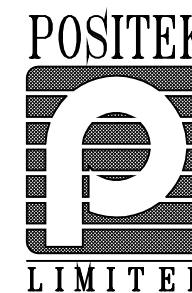

A	28/06/95		CHECKED BY	X	±0.4
B	04/10/11		RDM	X.X	±0.2
C	26/10/17			X.XX	±0.1
D	22/01/21				DIMS mm
			DESCRIPTION	TYPICAL TARGET TUBE FITTING OPTIONS	
SCALE			DRAWING NUMBER	P100-12	REV D
10mm					SHEET 1 OF 1

CHECKED
AT REV.

A

RDS

DRAWING NOT TO BE CHANGED WITHOUT REFERENCE TO THE CHANGE PROCEEDURE.
CHANGES TO PARTS USED IN INTRINSICALLY SAFE PRODUCT MUST BE APPROVED
BY THE AUTHORISED PERSON
THIS IS AN UNCONTROLLED PRINT AND WILL NOT BE UPDATED

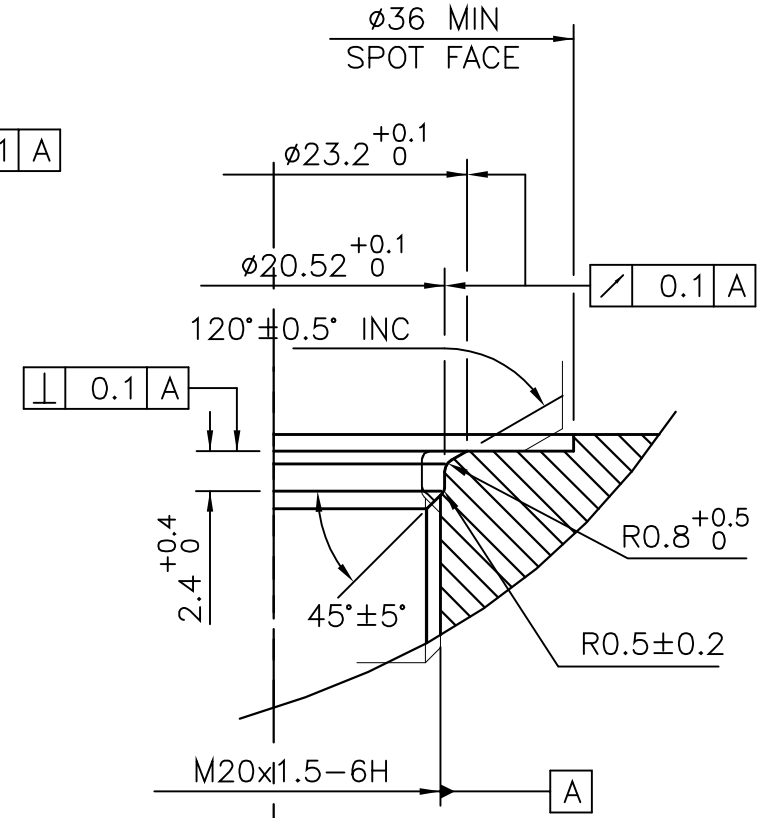
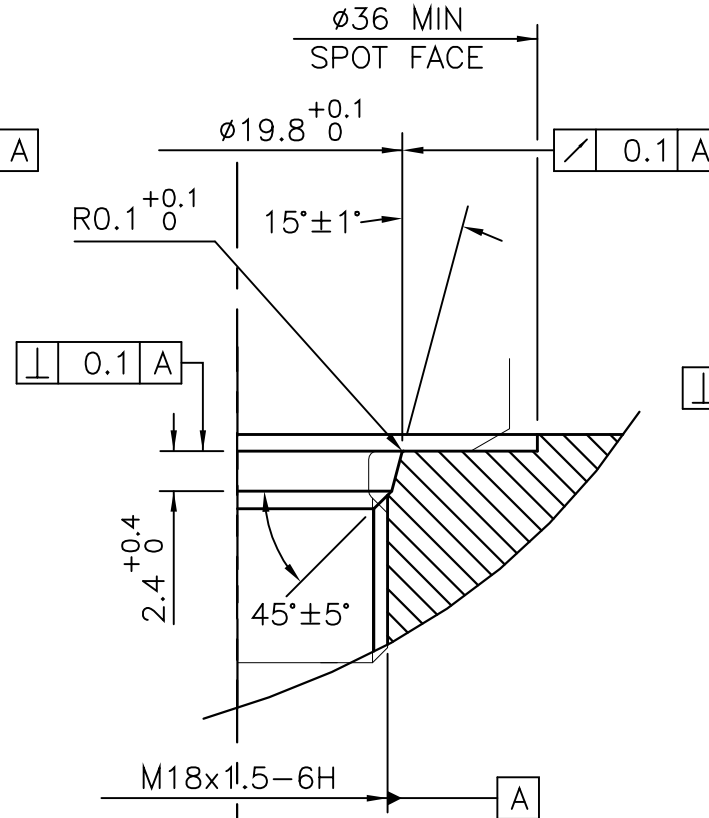
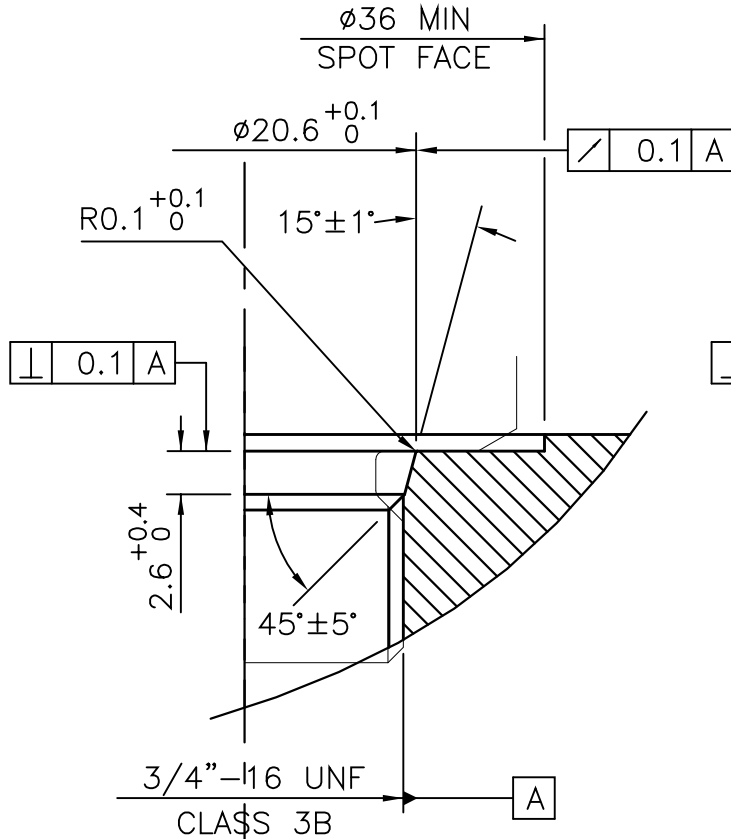

A	FIRST ISSUE	COH/DS
---	-------------	--------

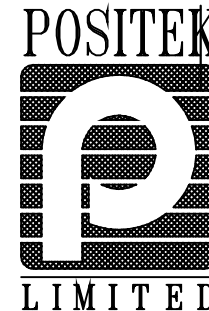

A	29/01/95	MATERIAL SEE NOTE 1	X ±0.4 X.X ±0.2 X.XX ±0.1 ALL DIMS mm
DESCRIPTION INSTALLATION DETAILS MOUNTING THREADS & SEALS		DRAWING NUMBER P100-15 REV A	
SCALE 5mm		SHEET 1 OF 1	

TARGET TUBE OPTION NOTES:-

- SPECIFY TUBE MATERIAL; CODE:-
'R' STAINLESS STEEL 316 ϕ 9.45.
'S' ALUMINIUM 6063 ϕ 3/8" (9.2-9.8). NOTE! ONLY AVAILABLE WITH P100 OR P106 VERSIONS.
- SPECIFY FLANGE TYPE; CODE: 'U', 'Vx', 'Wx' OR 'Xx' ~ SEE DETAILS BELOW.
- SPECIFY DIMENSION 'x' (mm), NOT APPLICABLE CODE 'U' PLAIN TUBE.

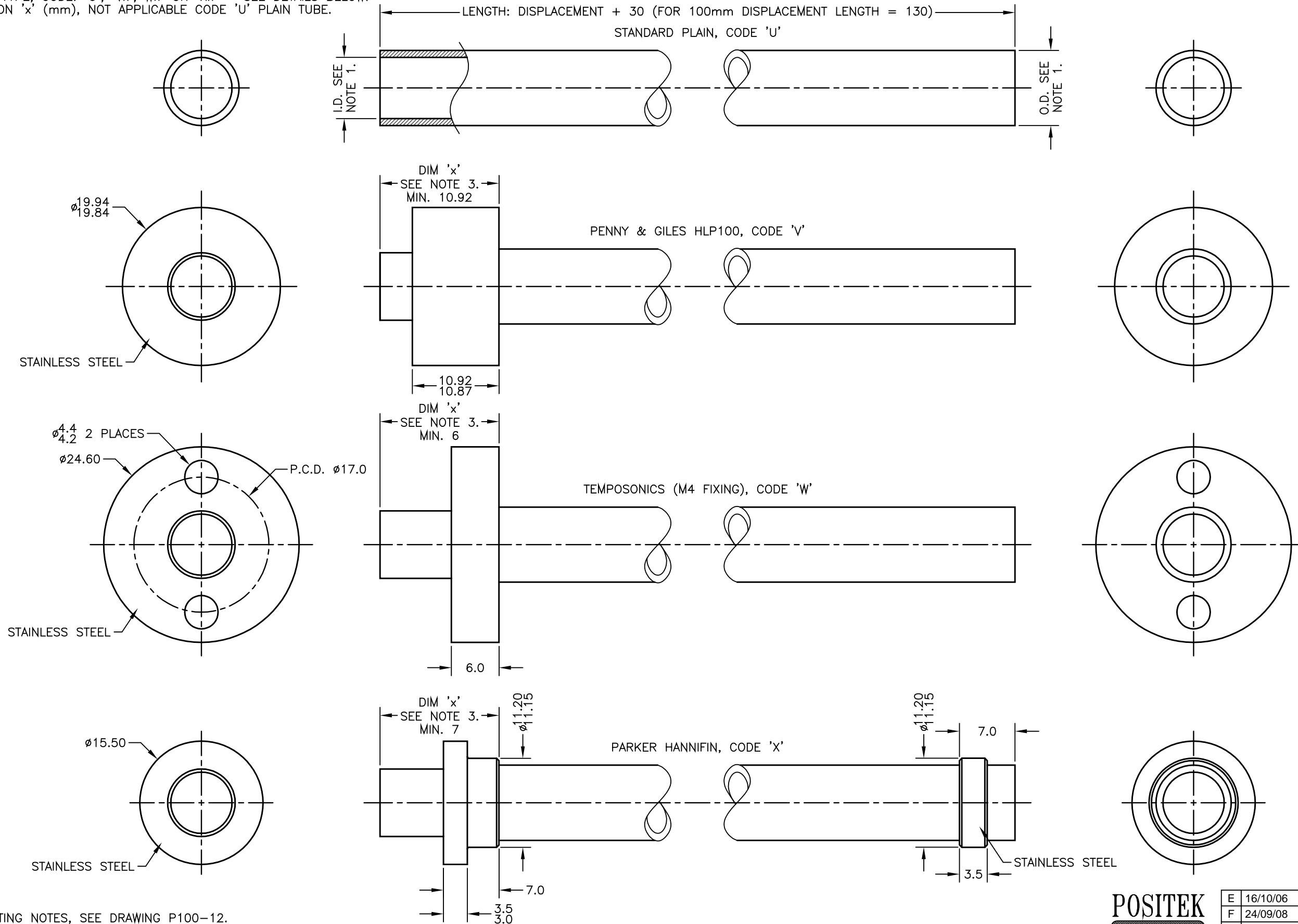

TARGET TUBE MOUNTING NOTES, SEE DRAWING P100-12.

E	MATERIAL OPTION REMOVED.	PDM
F	MAT'L OPTION REINSTATED RAN221.	PDM
G	X DIM FOR PH FLANGE SHOWN RAN225	RDS
H	9.45 WAS 9.5 RAN396	RDS
J	REDRAWN, PH FLANGE ROTATED RAN507.	PDM
K	NOTE 1 AMENDED ~ RAN1114.	PDM
L	'x' WAS 'n' ~ RAN1309	PDM

DRAWINGS NOT TO BE CHANGED WITHOUT REFERENCE TO THE CHANGE PROCEDURE.
CHANGES TO PARTS USED IN INTRINSICALLY SAFE PRODUCT MUST BE APPROVED
BY THE AUTHORISED PERSON
THIS IS AN UNCONTROLLED PRINT AND WILL NOT BE UPDATED.



E	16/10/06		CHECKED BY	X	± 0.4
F	24/09/08		RDM	X.X	± 0.2
G	13/11/08			X.XX	± 0.1
H	11/12/12				DIMS mm
J	23/07/14				
DESCRIPTION		TARGET TUBE AND FLANGE OPTIONS (LIPS 100/106)			
K	30/11/16				
L	08/11/22				
SCALE		DRAWING NUMBER			
5mm		TG24-11			
		REV L			
		SHEET 1 OF 1			



E100 CYLINDER - LINEAR POSITION SENSOR INTRINSICALLY SAFE FOR HAZARDOUS DUST ATMOSPHERES

- **Intrinsically safe for Gas and Dust to: Ex II 1GD**
- **Non-contacting inductive technology to eliminate wear**
- **Travel set to customer's requirement**
- **High durability and reliability**
- **High accuracy and stability**
- **Sealing to IP67**



As a leading designer and manufacturer of linear, rotary, tilt and intrinsically safe position sensors, Positek® has the expertise to supply a sensor to suit a wide variety of applications.

Our intrinsically safe E100 Linear Inductive Position Sensor incorporates electronics system EX07 which is ATEX / IECEx / UKEX approved for use in potentially explosive **gas/vapour and dust** atmospheres. The E100 is designed for demanding hydraulic or pneumatic cylinder position feedback applications where service life, environmental resistance and cost are important and is ideal for OEMs seeking good sensor performance for arduous applications in hazardous areas.

Overall performance, repeatability and stability are outstanding over a wide temperature range. The unit is highly compact and space-efficient, being responsive along almost its entire length. Like all Positek sensors, the E100 provides a linear output proportional to travel. Each unit is supplied with the output calibrated to the travel required by the customer, any stroke from 0-5mm to 0-800mm and with full EMC protection built in.

The sensor is very rugged, being made of stainless steel with an inert fluoropolymer-sheathed probe with a stainless steel target tube. The sensor is easy to install in cylinders and has a range of mechanical options. Environmental sealing is to IP67.

SPECIFICATION

Dimensions

Body diameter	35 mm
Body Length (to seal face)	43 mm
Probe Length (from seal face)	calibrated travel + 58 mm
Target Tube Length	calibrated travel + 30 mm

For full mechanical details see drawing E100-11

Independent Linearity

$\leq \pm 0.25\%$ FSO @ 20°C - up to 450 mm

$\leq \pm 0.5\%$ FSO @ 20°C - over 450 mm

Temperature Coefficients

$< \pm 0.01\%$ /°C Gain &

$< \pm 0.01\%$ /°C Offset

> 10 kHz (-3dB)

Frequency Response

Infinite

$< 0.02\%$ FSO

Ex II 1GD

Ex ia IIC T4 Ga (Ta= -40°C to 80°C)

Ex ia IIIC T135°C Da (Ta= -40°C to 80°C)

Approval only applies to the specified ambient temperature range and atmospheric conditions in the range 0.80 to 1.10 Bar, oxygen $\leq 21\%$

Sensor Input Parameters

Ui: 11.4V, Ii: 0.20A, Pi: 0.51W.

(connector option/s)

Ci: 1.16 μ F, Li: 50 μ H

(cable option/s)

Ci: 1.36 μ F, Li: 860 μ H with 1km max. cable

Environmental Temperature Limits

Operating -40°C to +80°C

Storage -40°C to +125°C

Sealing IP67

Hydraulic Pressure 350Bar

EMC Performance EN 61000-6-2, EN 61000-6-3

Vibration IEC 68-2-6: 10 g

Shock IEC 68-2-29: 40 g

MTBF 350,000 hrs 40°C Gf

Drawing List

E100-11 Sensor Outline

P100-12 Typical Target Installation details

P100-15 Mounting Thread details

TG24-11 Optional Target Tube Flange details

3D models, step or .igs format, available on request.

Do you need a position sensor made to order to suit a particular installation requirement or specification? We'll be happy to modify any of our designs to suit your needs - please contact us with your requirements.

For further information please contact:

www.positek.com sales@positek.com

Tel: +44(0)1242 820027 fax: +44(0)1242 820615

Positek, Andoversford Industrial Estate, Cheltenham GL54 4LB. U.K.





E100 CYLINDER - LINEAR POSITION SENSOR

INTRINSICALLY SAFE FOR HAZARDOUS DUST ATMOSPHERES

Intrinsically safe equipment is defined as "equipment which is incapable of releasing sufficient electrical or thermal energy under normal or abnormal conditions to cause ignition of a specific hazardous atmosphere mixture in its most easily ignited concentration."

ATEX / IECEx / UKEX approved to;

- Ex II 1GD
- Ex ia IIC T4 Ga (Ta= -40°C to 80°C)
- Ex ia IIIC T135°C Da (Ta= -40°C to 80°C)

Designates the sensor as belonging to; Group II: suitable for all areas **except mining**, Category 1 GD: can be used in areas with continuous, long or frequent periods of exposure to hazardous gas / vapour (Zones 2 to 0) and dust (Zone 20).

Gas / Vapour:

Protection class ia, denotes intrinsically safe for all zones

Apparatus group IIC: suitable for IIA, IIB and IIC explosive gas / vapour.

Temperature class T4: maximum sensor surface temperature under fault conditions 135°C.

Dust:

T135°C: maximum sensor surface temperature under fault conditions.

Ambient temperature range extended to -40°C to +80°C.

It is imperative Positek® intrinsically safe sensors be used in conjunction with a galvanic barrier to meet the requirements of the product certification. The Positek X005 Galvanic Isolation Amplifier is purpose made for Positek IS sensors making it the perfect choice. Refer to the X005 datasheet for product specification and output configuration options.

For cable lengths exceeding 10 metres a five wire connection is recommended to eliminate errors introduced by cable resistance and associated temperature coefficients.

ATEX / IECEx / UKEX approved sensors suitable for gas (X series) and mining (M series) applications, are also available from Positek.

E100	a	b	c	d	e	f	g	h
	Displacement	A	Y	Connections	Option	R	Option	Z000

a Displacement	Value	
Factory set to any length from 0-5 mm to 0-800 mm (e.g. 0-254 mm)	254	
b Output		
Supply V_{dc} (tolerance)	Output	Code
+5V (4.5 - 5.5V)	0.5 - 4.5V (ratiometric with supply)	A
Supply Current 10mA typical, 12mA max.		
c Calibration Adjustments		Code
Sealed		Y
d Connections		Code
Connector IP67 4 pin M12 IEC 61076-2-101, metal		J
Connector IP67 4 pin M12 IEC 61076-2-101, metal, pre-wired 3-core cable		Jxx
Connector IP67 4 pin M12 IEC 61076-2-101, metal, pre-wired 5-core cable		JQxx
Cable gland IP67 Pg9, metal, 3-core cable		Lxx
Cable gland IP67 Pg9, metal, 5-core cable		LQxx
Cable gland, short† IP67, metal, 3-core cable		Mxx
Cable gland, short† IP67, metal, 5-core cable		MQxx
Specify required cable length 'xx' in cm. e.g. L2000 specifies axial cable gland with 20 m of cable, 50 cm supplied as standard. Note! maximum length supplied 15000cm. †Nb: restricted cable pull strength.		

e Mounting Thread		Code
M20 x 1.5		N
3/4 16 UNF	Hex. 30 mm A/F, Ø 30 mm seal face. Supplied with O-ring seal.	P
M18 x 1.5		T
See P100-15 Drawing for Mating Thread Details.		
f Target Tube		Code
Stainless Steel 316 O.D.: 9.45 mm		R
See P100-12 Drawing for Typical Target Installation details.		
g Target Tube Mounting Flange		Code
None		U
Penny & Giles HLP100		Vxx
Temposonics (M4 fixing)	Please specify flange position in mm. eg. W17.5 specifies a Tempo style flange fitted 17.5 mm from the front face	Wxx
Parker Hannifin		Xxx
See TG24-11 Drawing for Target Details.		
h Z-code		Code
Calibration to suit X005 required		Z000
Tighter Independent Linearity; $\leq \pm xx\%$ FSO @20°C		
$\leq \pm 0.1\%$ 0 - 10 mm min. to 0 - 450 mm		
$\leq \pm 0.25\%$ 0 - 451 mm to 0 - 600 mm		
$\leq \pm 0.5\%$ 0 - 601 mm to 0- 800 mm max.		

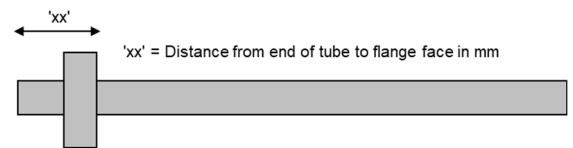
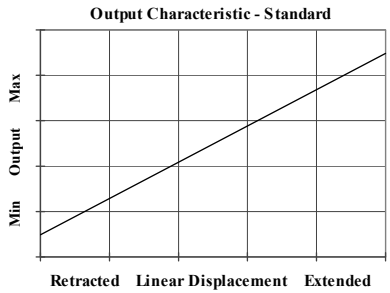

For further information please contact:

www.positek.com sales@positek.com

Tel: +44(0)1242 820027 fax: +44(0)1242 820615

Positek, Andoversford Industrial Estate, Cheltenham GL54 4LB. U.K.



Three or Five-Wire Mode Connection

FOR INTRINSICALLY SAFE SENSORS IN HAZARDOUS ATMOSPHERES

The aim of this document is to help readers who do not understand what is meant by three or five wire modes of connection between the galvanic isolation amplifier and sensor, and the factors behind them. It is by no means an in-depth technical analysis of the subject.

Whether opting for a pre-wired Positek® Intrinsicly Safe sensor or one with a connector, choosing the right mode of connection and cable to suit the application requires careful consideration.

Interconnecting cables are not perfect conductors and offer resistance to current flow, the magnitude of resistance[†] depends on conductors resistivity, which changes with temperature, cross sectional area[‡] and length. If the voltage were to be measured at both ends of a length of wire it would be found they are different, this is known as volts drop. Volts drop changes with current flow and can be calculated using Ohm's law, it should be noted that volts drop occurs in both positive and negative conductors. The effects of volts drop can be reduced by increasing the conductors cross sectional area, this does not however eliminate the effects due to temperature variation. There are instances where large cross-section cables are not practical; for example most standard industrial connectors of the type used for sensors have a maximum conductor capacity of 0.75mm², copper prices and ease of installation are other considerations.

This is important because the effects of volts drop can significantly alter the perceived accuracy of the sensor which is ratiometric i.e. the output signal is directly affected by the voltage across the sensor. Changes in temperature will also be seen as gain variation in the sensor output.

Three wire mode connections are common and are suitable in most cases with short or moderate cable runs. Applications that do not require a high degree of accuracy but have cable runs, say in excess of 10m, volts drop can be reduced by introducing a terminal box close to the sensor and using a larger cross-section cable for a majority of the cable run. Sensors supplied with three core cable are calibrated with the cable fitted which largely eliminates errors due to conductor resistance at room temperature however, as mentioned above, small gain errors due to temperature fluctuations should be expected.

Five wire mode connections have significant benefits as losses in the positive and negative conductors are compensated for by the galvanic isolation amplifier which can 'sense' the voltage across the sensor and dynamically adjust the output voltage so that the voltage across the sensor is correct. The effects of cable resistance and associated temperature coefficients are eliminated allowing for smaller conductors than a three wire connection for the same cable run. The amplifier can compensate for up to 15Ω per conductor with a current flow of 15mA, which is more than adequate for 150m of 0.25 mm² cable, longer lengths will require larger conductors.

For this reason Positek® recommends five wire connections for cable lengths exceeding 10 metres in 0.25 mm² cable to preserve the full accuracy of the sensor.

See illustrations below for examples of connecting a sensor to the galvanic isolation amplifier.

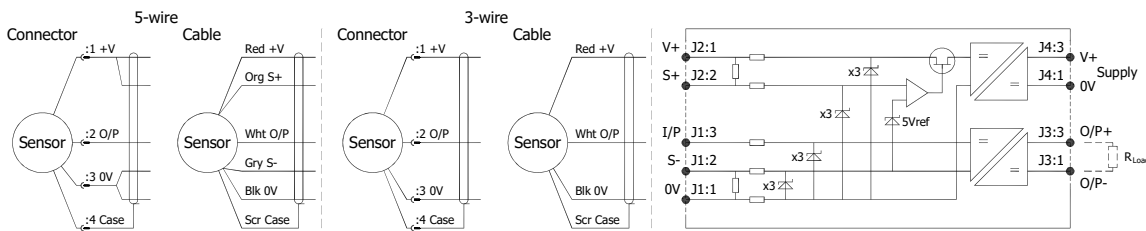

Cable Length (metres)	Up to 150	150 - 300	300 - 450	450 - 600	600 - 900	900 - 1000
Cross Section (mm ²)	0.25	0.5	0.75	1.0	1.5	2.0

The table above shows recommended conductor sizes with respect to cable length for both three and five wire connections, based on copper conductors. Three wire connections will introduce a gain reduction of 5% and a ±1% temperature dependence of gain over the range -40°C to +80°C for the cable temperature. (i.e. about -150 ppm/°C for the maximum lengths shown and less pro rata for shorter lengths.)

It should be noted that the maximum cable length, as specified in the sensor certification, takes **precedence** and **must not** be exceeded.

Positek® sensors are supplied with three core 0.25 mm² cable as standard, however five core 0.25 mm² cable can be supplied on request. The galvanic isolation amplifier is available as;

G005-*** for 'G' and 'H' prefix sensors
X005-*** for 'E', 'M' and 'X' prefix sensors

[†] $R = \rho L/A$ ρ is the resistivity of the conductor (Ωm) L is the length of conductor (m) A is the conductor cross-sectional area (m²).

[‡] It is presumed that direct current flow is uniform across the cross-section of the wire, the galvanic isolation amplifier and sensor are a dc system.



For further information please contact:

www.positek.com sales@positek.com

Tel: +44(0)1242 820027 fax: +44(0)1242 820615

Positek, Andoversford Industrial Estate, Cheltenham GL54 4LB. U.K.



Installation Information

E100 CYLINDER – LINEAR POSITION SENSOR

INTRINSICALLY SAFE FOR HAZARDOUS DUST ATMOSPHERES

For certificate number and safety parameters information for product marked EX04, see next page.

ATEX / IECEx / UKEX Qualified to Intrinsic Safety Standard Certificate numbers SIRA 13ATEX2371X IECEX SIR 13.0154X CSAE 21UKEX2537X		Ex II 1GD Ex ia IIC T4 Ga (Ta = -40°C to +80°C) Ex ia IIIC T135°C Da (Ta = -40°C to +80°C)	
Electronics Version	Output Description:	Supply Voltage: Vs (tolerance)	Load resistance:
EX07	0.5 - 4.5V (ratiometric with supply) [Output code 'A']	+5V (4.5 - 5.5V)	5kΩ min

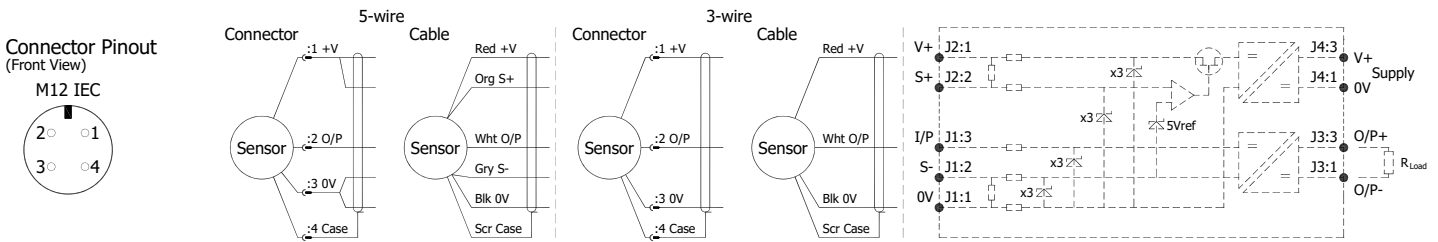

Putting Into Service: The sensor must be used with a galvanic isolation barrier designed to supply the sensor with a nominal 5V and to transmit the sensor output to a safe area. The barrier parameters must not exceed:-

Ui = 11.4V **Ii = 0.20A** **Pi = 0.51W**
Ci = 1.36µF* **Li = 860µH*** (with maximum cable length)
Ci = 1.16µF **Li = 50µH** (without cable)

*Figures for 1km cable where: Ci = 200pF/m & Li = 810nH/m

The sensor is certified to be used with up to **1000m** of cable, cable characteristics must not exceed:-

Capacitance: ≤ 200 pF/m or max. total of: 200 nF
 Inductance: ≤ 810 nH/m or max. total of: 810 µH

Approval only applies to specified ambient temperature range and atmospheric conditions in the range: 0.80 to 1.10 Bar, oxygen ≤ 21%.

The performance of the sensor may be affected by voltage drops associated with long cable lengths; For cable lengths exceeding 10 metres a five wire connection is recommended to eliminate errors introduced by cable resistance and associated temperature coefficients.

Warning - The M12 IEC connector may be rotated for purposes of convenient orientation of the connector and cable, however rotating the connector more than one complete revolution is not recommended. **Repeated rotation of the connector will damage the internal wiring!**

Special Condition for Safe Use:

The apparatus does not meet the 500 V r.m.s dielectric strength test between circuit and frame, in accordance with clause 6.3.13 of IEC 60079-11:2011. This must be taken into consideration on installation.

When using a Sensor that has an integral cable in a dust application, the free end of the cable shall be appropriately terminated for the zone of use. Under certain extreme circumstances, the non-metallic and isolated metal parts incorporated in the enclosure of this equipment may generate an ignition-capable level of electrostatic charge. Therefore the equipment shall not be installed in a location where the external conditions are conducive to the build-up of electrostatic charge on such surfaces. This is particularly important if the equipment is installed in a zone 0 location. In addition, the equipment shall only be cleaned with a damp cloth.

Use: The sensor is designed to measure linear displacement and provide an analogue output signal.

Assembly and Dismantling: The unit is not to be serviced or dismantled and re-assembled by the user.

Maintenance: No maintenance is required.

Mechanical Mounting: Via mounting thread, maximum tightening torque: 100Nm. See drawing P100-15, Installation Details Mounting Threads & Seals. An O ring seal is provided, size BS908 for M20 & 3/4 UNF thread or 14.3 x 2.4 for M18 thread. Install the target tube using the flange provided or fix directly into the piston rod using adhesive for instance, the end of the target tube can be proud or flush with the piston end face as required - see drawing P100-12.

Output Characteristic: Target position at start of normal travel is 36.0 mm from seal face. The output increases as the target is moved away from the sensor body, the calibrated stroke is between 5 mm and 800 mm.

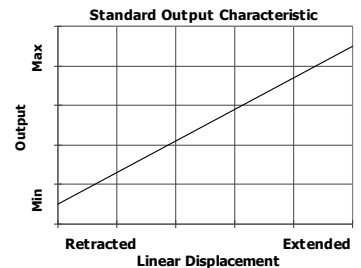

Incorrect Connection Protection levels: Not protected – the sensor is **not** protected against either reverse polarity or over-voltage. The risk of damage should be minimal where the supply current is limited to less than 50mA.



For further information please contact:
www.positek.com sales@positek.com
 Tel: +44(0)1242 820027 fax: +44(0)1242 820615
 Positek, Andoversford Industrial Estate, Cheltenham GL54 4LB. U.K.



Installation Information

E100 CYLINDER – LINEAR POSITION SENSOR

INTRINSICALLY SAFE FOR HAZARDOUS DUST ATMOSPHERES

For certificate number and safety parameters information for product marked EX07, see previous page.

ATEX Qualified to Intrinsic Safety Standard Certificate numbers SIRA 00ATEX2076X		Ex II 1GD EEx ia IIC T4 (Ta = -40°C to +80°C) Ex ia D 20 T135°C (Ta= -40°C to +80°C)	
Electronics Version	Output Description:	Supply Voltage: <i>V_s</i> (tolerance)	Load resistance:
EX04	0.5 - 4.5V (ratiometric with supply) [Output code 'A']	+5V (4.5 - 5.5V)	5kΩ min

The barrier parameters must not exceed:-

U_i = 11.4V **I_i = 0.20A** **P_i = 0.51W**
C_i = 1.36μF* **L_i = 710μH*** ('Lxx' option) *Figures for 1km cable
C_i = 1.16μF **L_i = 50μH** ('J' option)

The sensor is certified to be used with up to **1000m** of cable, cable characteristics must not exceed:-

Capacitance: ≤ 200 pF/m for max. total of: 200 nF
 Inductance: ≤ 660 nH/m for max. total of: 660 μH

With the exception of the certificate number and safety parameters above, all other notes regarding Putting Into Service, Use, Assembly and Dismantling etc. on previous page apply to sensors marked EX04 or EX07.



For further information please contact:

www.positek.com sales@positek.com

Tel: +44(0)1242 820027 fax: +44(0)1242 820615

Positek, Andoversford Industrial Estate, Cheltenham GL54 4LB. U.K.